

High energy efficiency with maintenance-free 3 Phase AC drive motor

Effortless operation with electric steering and JetPilot

Safe travel characteristics when cornering with Curve Control

Electronic SpeedControl giving smooth operation

Semi-automatic remote coupling release directly from operator platform (optional)



EZS 350

Tow tractor (5000 kg)

The Jungheinrich EZS 350 is a versatile, economic tow tractor for towing trailers up to 5000 kg. The ability to couple several trailers together, provides a flexible materials handling operation.

The coupling is visible from every position and is easily accessible. The semi-automatic remote release (optional) facilitates the coupling/releasing of trailers without the operator having to leave the platform, saving time and costs. Another advantage is that the tow tractor is available with

several different couplings and can therefore be adjusted to any type of trailer.

The truck's high performance is down to the 3 Phase AC drive motor. The advantages are powerful acceleration and high top speed, with significant energy saving, extended operating times and low maintenance (through omission of carbon brushes). This is due to the optimised set up between drive motor and the electronic controller and regenerative braking.

Main ergonomic advantages are the low stand-on platform for frequent mounting and dismounting and the short distance from operator's platform to load.

The EZS also operates effortlessly in tight spaces. The turning radius is so small that the operator gets the impression that he is turning on the spot. The JetPilot steering wheel, supportive backrest and automatic speed reduction "Curve Control" all provide comfort and safety, especially on corners.

EZS 350

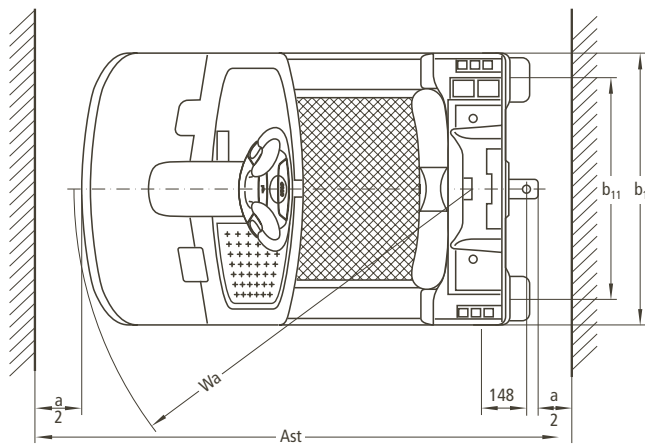
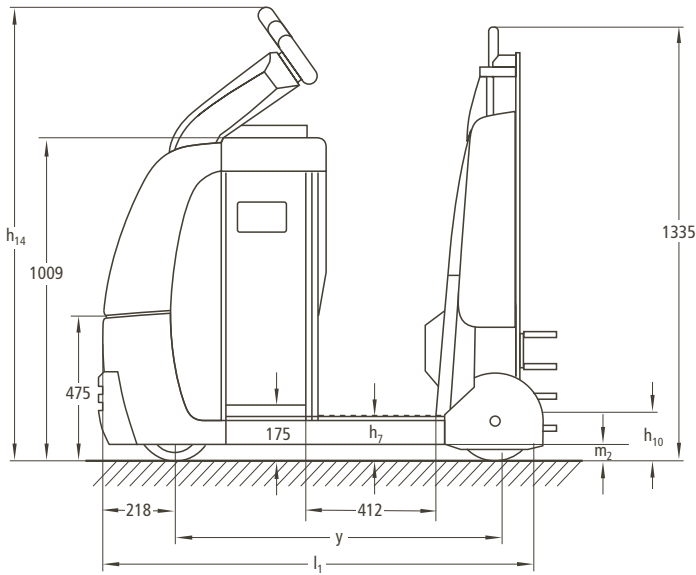

Performance diagram EZS 350

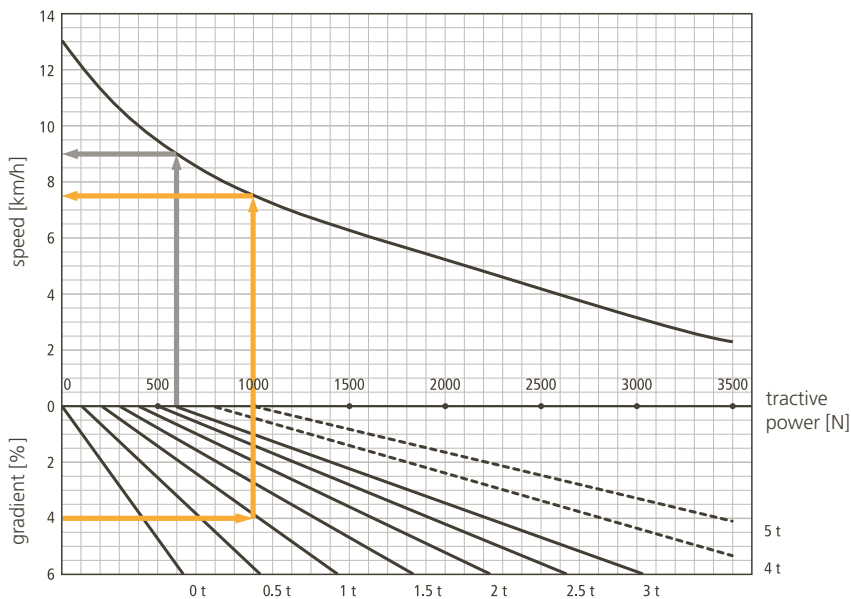

How to read the diagram:

1. The EZS travels on level ground with a 3000 kg load. It requires 600 N tractive power for this and reaches approx. 9 km/h.
2. The EZS is to travel up a 4% gradient with a 1000 kg load. The EZS requires 1000 N tractive power for this and will reach approximately 7.5 km/h.

Note:
No continuous operation possible for EZS 350 over 1000 N.

The utilisation of braked trailers is recommended for up/down gradients of more than 4%!

Technical Data in line with VDI 2198 as at: 06/2010

Identification	1.1	Manufacturer (abbreviation)		Jungheinrich	Jungheinrich	1.1
	1.2	Manufacturer's type designation		EZS 350	EZS 350 XL	1.2
	1.3	Drive		electric	electric	1.3
	1.4	Type of operation		stand-on	stand-on	1.4
	1.5	Load capacity/load	Q (t)	5.0	5.0	1.5
	1.7	Rated drawbar pull	F (N)	1000	1000	1.7
	1.9	Wheelbase	y (mm)	980	1147	1.9
Weights	2.1	Service weight incl. battery (see line 6.5)	kg	976	1110	2.1
	2.3	Axle loading, unladen front/rear	kg	520/456	590/520	2.3
Wheels, Chassis	3.1	Tyres		Vulkollan®, superelastic ⁷⁾	Vulkollan®, superelastic ⁷⁾	3.1
	3.2	Tyre size, front	mm	Ø230x77	Ø230x77	3.2
	3.3	Tyre size, rear	mm	Ø250x80	Ø250x80	3.3
	3.5	Wheels, number front/rear (x = driven wheels)		1x/2	1x/2	3.5
	3.7	Track width, rear	b ₁₁ (mm)	680	680	3.7
Basic Dimensions	4.8	Seat height/standing height	h ₇ (mm)	-/132	-/132	4.8
	4.9	Height of tiller in drive position min./max.	h ₁₄ (mm)	1399 ¹⁾	1444 ¹⁾	4.9
	4.12	Coupling height	h ₁₀ (mm)	158 ⁵⁾	158 ⁵⁾	4.12
	4.19	Overall length	l ₁ (mm)	1350 ²⁾	1517 ²⁾	4.19
	4.21	Overall width	b ₁ /b ₂ (mm)	810/-	810/-	4.21
	4.32	Ground clearance, centre of wheelbase	m ₂ (mm)	50	50	4.32
	4.35	Turning radius	Wa (mm)	1220	1370	4.35
Performance Data	5.1	Travel speed, laden/unladen	km/h	7.0/12.5 ³⁾	7.0/12.5 ³⁾	5.1
	5.5	Drawbar pull, laden/unladen	N	1000 ⁴⁾	1000 ⁴⁾	5.5
	5.6	Max. drawbar pull, laden/unladen	N	3200 ³⁾	3200 ³⁾	5.6
	5.7	Gradient performance, laden/unladen	%	- ³⁾	- ³⁾	5.7
	5.8	Max. gradient performance, laden/unladen	%	- ³⁾	- ³⁾	5.8
5.10	Service brake		electromagnetic	electromagnetic	5.10	
E-Motor	6.1	Drive motor rating S ₂ 60 min.	kW	2.8	2.8	6.1
	6.3	Battery acc. to DIN 43531/35/36 A, B, C, no		no	no	6.3
	6.4	Battery voltage, nominal capacity K ₅	V/Ah	24/465	24/620	6.4
	6.5	Battery weight	kg	370	470	6.5
	6.6	Energy consumption acc. to VDI cycle	kWh/h	0.97 ⁶⁾	0.97 ⁶⁾	6.6
Others	8.1	Type of drive control		AC SpeedControl	AC SpeedControl	8.1
	8.4	Sound level at driver's ear according to EN 12053	dB (A)	66	66	8.4

- 1) height JetPilot
2) total length without coupling, as different coupling types are available
3) see diagram
4) nominal tractive power
5) other coupling heights available
6) at 9 km/h
7) drive wheel: Vulkollan®; load wheels: superelastic

Make use of the advantages

Innovative 3 Phase AC technology

Jungheinrich motors with AC technology provide increased efficiency with reduced operating costs whilst making use of the following advantages:

- High efficiency factor with excellent energy management.
- Powerful acceleration.
- Quick travel direction change without any time for pause.
- No carbon brushes – the drive motor is maintenance-free.
- 2-year warranty on drive motor.

Comfortable and safe travelling

The electronic SpeedControl and automatic speed reduction in corners Curve Control facilitate comfortable, safe travelling with adjustment for every application:

- The travel speed set by the driver on the control switch is maintained irrespective of operation eg. during travel; up or down an incline or ramp.
- 3 adjustable travel programs for individual adjustment to any requirement.
- Regenerative braking with energy reclamation on deceleration.
- Safe cornering; the tractor always remains under the control of the operator.

Optimised ergonomics

- Low stand-on platform for frequent effortless mounting and dismounting.
- Short distances for the operator from the driving position to the coupling or load.
- The coupling can be seen from every position and is easily accessible.



JetPilot steering wheel

- Fast, easy coupling/decoupling of trailers with semi-automatic remote unlocking from the driving position.
- Electric steering with JetPilot steering wheel.
- Different couplings for different trailer types.
- CSE load wheels for excellent travel comfort.

Robust construction for the hardest applications

- Chassis made of high-quality 8mm steel plate.
- Extra high drawn up chassis apron at front cover.

Long operating times

- Energy-saving 3 Phase AC technology and high battery capacities facilitate long operating times:
- Standard version: 3 PzS 465 Ah.

Informed at any time

Extensive display provides a complete overview:

- CanDis (optional) informs about state of battery discharge, operating hours and fault codes.
- Truck activation via PIN and selection of 3 travel programmes via keyboard (optional).
- Adjustable travel parameters with CanDis and CanCode (optional).

Additional equipment

Extensive accessories facilitate individual adjustments to your application:

- Rear inching via buttons in the backrest on both sides.
- Semi-automatic remote unlocking of coupling.
- Additional collision protection made of steel and/or rubber.
- Holder for radio data transmission equipment.



Different couplings available (optional)

Jungheinrich UK Ltd.

Head Office:

Sherbourne House · Sherbourne Drive
Tilbrook · Milton Keynes MK7 8HX
Phone 01908 363100
Fax 01908 363180

info@jungheinrich.co.uk
www.jungheinrich.co.uk



Jungheinrich trucks conform to the European Safety Requirements.

JUNGHEINRICH
Well worthwhile