

**Powerful maintenance-free
3-phase AC motor**

**Extremely manoeuvrable
due to compact chassis design**

**Easy operation with the tiller
in the upright position
by using the crawl speed button**

**Excellent stability on cornering
with ProTraLink**

**Multi-shift operation with
sideways battery exit (optional)**



EJE 116/118/120

Electric pedestrian controlled operated pallet truck (1600, 1800 and 2000 kg)

The EJE 1 Series pallet trucks are particularly suited to lorry loading and offloading as well as horizontal transport over short distances. The main advantage is down to its short chassis length (L_2) of only 480 mm, the EJE can be manoeuvred in the smallest of spaces.

The innovative 3-phase AC drive motor is another advantage. Its efficiency ensures high speed and powerful acceleration in every situation – ideal for fast, efficient product throughput. Added to speed of operation are long operating times: bat-

teries up to 250 Ah in combination with excellent energy management ensure long operating times. For operations lasting more than 1 shift, the battery can be removed sideways for quick battery change (optional for EJE 120).

The long tiller ensures safe operation by keeping a practical distance between operator and truck. If space is at a premium, the crawl speed button makes travelling safe with the tiller in the upright position. One touch of a button is sufficient: the brake is released and the drive switch au-

tomatically controls travel at a reduced speed. The low battery height pays off particularly in confined spaces, and provides even the shorter operator with optimum visibility towards the fork tips.

The completely redeveloped multifunction tiller head is full of innovations: enclosed sensor system (IP 65) for protection against breakdown, rocker switch with contactless electronics for operation in every tiller position and ergonomically arranged switches.

EJE 116/118/120

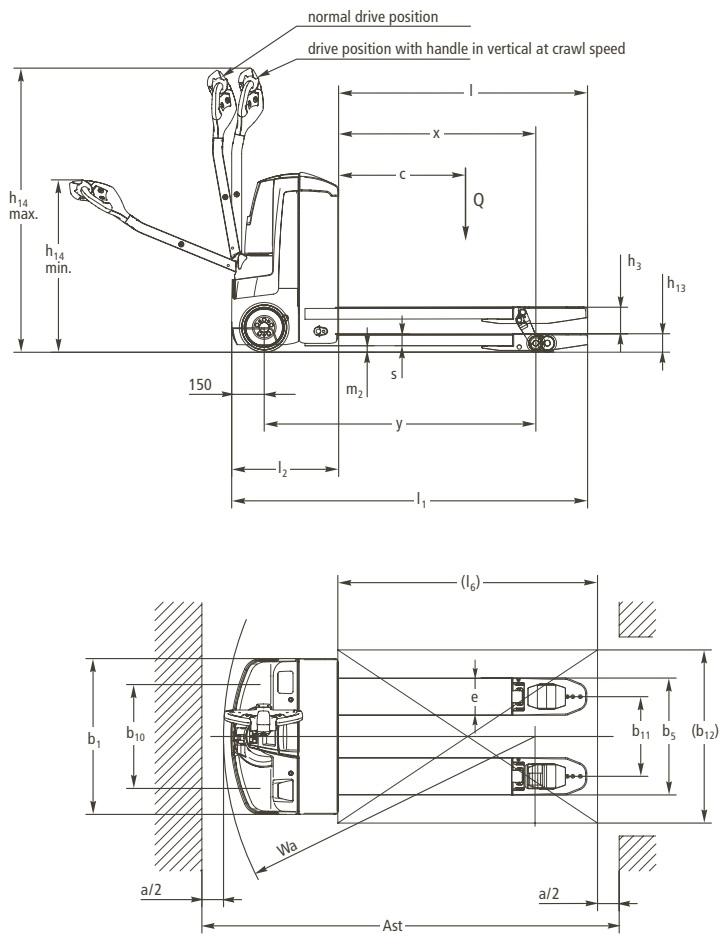

Technical data in line with VDI 2198 as at: 04/2010

Identification	1.1	Manufacturer (abbreviation)	Jungheinrich	Jungheinrich	Jungheinrich	1.1	
	1.2	Manufacturer's type designation	EJE 116	EJE 118	EJE 120	1.2	
	1.3	Drive	electric	electric	electric	1.3	
	1.4	Operator type	pedestrian	pedestrian	pedestrian	1.4	
	1.5	Load capacity/rated load	Q (t)	1.6	1.8	2.0	1.5
	1.6	Load centre distance	c (mm)	600	600	600	1.6
	1.8	Load distance, centre of drive axle to fork	x (mm)	911 ¹⁾	911 ¹⁾	911 ¹⁾	1.8
	1.9	Wheelbase	y (mm)	1255 ¹⁾²⁾	1255 ¹⁾²⁾	1255 ¹⁾²⁾	1.9
	Weights	2.1	Service weight incl. battery (see line 6.5)	kg	439	441	441
2.2		Axle loading, laden front/rear	kg	737/1302	787/1454	809/1632	2.2
2.3		Axle loading, unladen front/rear	kg	346/93	347/94	347/94	2.3
Wheels, Chassis	3.1	Tyres	PU/PU	PU/PU	PU/PU	3.1	
	3.2	Tyre size, front	230x70	230x70	230x70	3.2	
	3.3	Tyre size, rear	85 x 110/85 x 85	85 x 110/85 x 85	85 x 110/85 x 85	3.3	
	3.4	Additional wheels (dimensions)	100x40	100x40	100x40	3.4	
	3.5	Wheels, number front rear (x = driven wheels)	1x + 2/2 or 4	1x + 2/2 or 4	1x + 2/2 or 4	3.5	
	3.6	Tread, front	b ₁₀ (mm)	508	508	508	3.6
	3.7	Tread, rear	b ₁₁ (mm)	368	368	368	3.7
Basic Dimensions	4.4	Lift	h ₃ (mm)	122	122	122	4.4
	4.9	Height of tiller in drive position min./max.	h ₁₄ (mm)	797/1313	797/1313	797/1313	4.9
	4.15	Height, lowered	h ₁₃ (mm)	85	85	85	4.15
	4.19	Overall length	l ₁ (mm)	1644 ²⁾	1644 ²⁾	1644 ²⁾	4.19
	4.20	Length to face of forks	l ₂ (mm)	494 ²⁾	494 ²⁾	494 ²⁾	4.20
	4.21	Overall width	b ₁ (mm)	720	720	720	4.21
	4.22	Fork dimensions	s/e/l (mm)	55 x 172 x 1150	55 x 172 x 1150	55 x 172 x 1150	4.22
	4.25	Distance between fork-arms	b ₅ (mm)	540	540	540	4.25
	4.32	Ground clearance, centre of wheelbase	m ₂ (mm)	30	30	30	4.32
	4.33	Aisle width for pallets 1000 x 1200 crossways	A _{st} (mm)	1879 ²⁾	1879 ²⁾	1879 ²⁾	4.33
	4.34	Aisle width for pallets 800 x 1200 lengthways	A _{st} (mm)	1929 ²⁾	1929 ²⁾	1929 ²⁾	4.34
4.35	Turning radius	Wa (mm)	1440 ²⁾	1440 ²⁾	1440 ²⁾	4.35	
Performance Data	5.1	Travel speed, laden/unladen	km/h	6.0/6.0	6.0/6.0	6.0/6.0	5.1
	5.2	Lift speed, laden/unladen	m/s	0.04/0.05	0.04/0.05	0.04/0.05	5.2
	5.3	Lowering speed, laden/unladen	m/s	0.05/0.04	0.05/0.04	0.05/0.04	5.3
	5.8	Max. gradeability, laden/unladen	%	10/20	9/20	8/20	5.8
	5.10	Service brake		electric	electric	electric	5.10
Electric Engine	6.1	Drive motor rating S ₂ 60 min.	kW	1.0	1.0	1.0	6.1
	6.2	Lift motor rating at S ₃ 10 %	kW	1.2	1.2	1.2	6.2
	6.3	Battery acc. to DIN 43531/35/36 A, B, C, no		no/B	no/B	no/B	6.3
	6.4	Battery voltage, nominal capacity K _s		24/150	24/150	24/150	6.4
	6.5	Battery weight	kg	151	151	151	6.5
	6.6	Energy consumption acc. to VDI cycle	kWh/h	0.36	0.4	0.44	6.6
Others	8.1	Type of drive control		AC SpeedControl	AC SpeedControl	AC SpeedControl	8.1
	8.4	Sound level at the driver's ear according to EN 12 053	dB(A)	70	70	70	8.4

1) load section lowered: + 53 mm

2) battery compartment M (250 Ah): + 71 mm

Make use of the advantages



Powerful due to innovative 3-phase AC technology

Innovative 3-phase AC technology

Jungheinrich motors in 3-phase AC technology provide increased efficiency with reduced operating costs at the same time:

- Highly efficient with excellent management of energy resources.
- Powerful acceleration.
- Quick direction change without the usual time delay.
- No carbon brushes – the drive motor is maintenance-free.
- 2-year warranty on drive motor.

Long operating times

The energy-saving 3-phase AC technology in combination with battery capacities of up to 250 Ah gives long operating times:

- Short version S: 2 PzB 130/150 Ah.
- Medium version M: 2 PzS 180/250 Ah, available as an option with sideways battery removal on EJE 120.
- Integrated charger (24V/30A for wet batteries and maintenance-free batteries) for easy charging at any mains socket (optional).

Well informed at any time

Extensive monitoring display and adjustable controls at a glance:

- Combined battery discharge indicator (3 colour LCD) with lift cut-off and charge condition display (for integrated charger).

- Information display "CanDis" (optional) with additional operating hour display and fault code data memory.
- Activation of truck via PIN and choice of 3 travel programmes via "CanCode" (optional).
- Adjustable travel parameters with CanDis and CanCode (optional).

Optimum cornering

Sprung and cushioned support wheels linked via the torsion bar suspension



Combined discharge indicator with state of charge display

"ProTraLink" distribute stabilising forces dependent on travel conditions i.e. evenly over all wheels during straight travel; concentrated on the outer support wheel during cornering.

Ergonomic operation

The redeveloped tiller head is perfectly adjusted to operator requirements:

- Clear colour coded buttons with abrasion resistant symbols for intuitive control.
- Handle position adjusted to suit natural operation.
- Crawl speed button on the underside of the tiller head for quick access and easy operation with the tiller in the vertical position.
- The tiller head also has excellent protection against breakdown with a contactless



Ergonomic tiller head

sensor system which has IP 65 protection against water ingress.

- Rocker switch for smooth operation in any tiller position.

Reduced maintenance

3-phase AC technology ensures significant long-term reduction in operating costs:

- Maintenance-free 3-phase AC drive motor with no carbon brushes.
- Easy access to all components through one-piece front cover held by only two screws.
- Secure protection from dust and damp due to enclosed controls and plugs according to IP 54.
- ProTraLink also ensures low support wheel damage during ramp work due to its self levelling adjustment. A torsion bar constantly keeps both support wheels at the same height reducing the chance of catching or damage to the lower support wheel.

Additional equipment

- Buzzer instead of horn.
- Special switch for easy release of brake.
- Vertical load guard.
- Cold store design.

Jungheinrich UK Ltd.

Head Office:

Sherbourne House · Sherbourne Drive
Tilbrook · Milton Keynes MK7 8HX
Phone 01908 363100
Fax 01908 363180

info@jungheinrich.co.uk
www.jungheinrich.co.uk



Jungheinrich trucks conform to the European Safety Requirements.

JUNGHEINRICH
Well worthwhile