

**Powerful and economical with maintenance free 3-phase AC drive motor**

**Sensitive lifting and lowering from the tiller buttons via adjustable hydraulic motor speed**

**Efficient and quiet hydraulics**

**High residual capacities at high lift heights**

**Effortless electric steering (optional)**



## **EJC 212/214/216/220**

### **Electric pedestrian stacker (1200, 1400, 1600 and 2000 kg)**

The EJC 2 series pedestrian stackers are specially designed for increased productivity at high lift heights, high residual capacities and long operating times. With their narrow width of only 800 mm (EJC 220: 820 mm) they have the capability of manoeuvring safely and effortlessly in the most confined spaces with the tiller in the upright position.

A powerful 3-phase AC drive motor is an added bonus. Its excellent efficiency ensures high speed with good acceleration

in every application – the best basis for fast, efficient goods throughput.

Other advantages as a result of the high specification lifting system:

- Exact and sensitive lifting of the load. This allows easy stacking in narrow racking.
- Minimum noise during lifting.
- Higher lowering speed without load. The faster lowering of unladen forks, speeds up cycle times.

- Gentle depositing of load/forks on the floor or in the racking with proportional hydraulics.

The EJC 212/214/216/220 takes the required energy from batteries with capacities up to 375 Ah. An integrated charger (optional) provides easy and reliable charging at any 13 amp plug socket.

# EJC 212/214/216/220

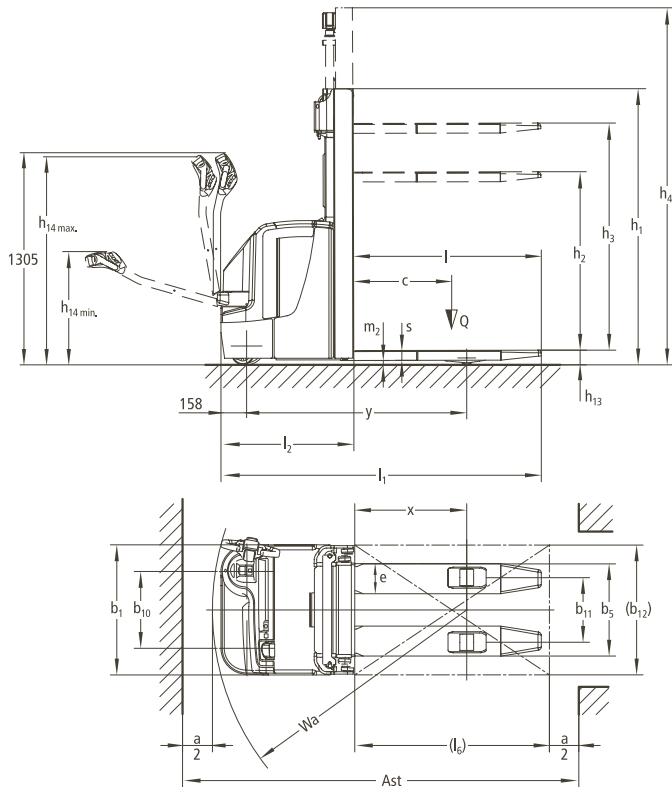

Standard mast types (mm)												
Designation	Closed height $h_1^*$	Free lift $h_2$	Lift height $h_3$	Extended height $h_4$	Closed height $h_1^*$	Free lift $h_2$	Lift height $h_3$	Extended height $h_4$	Closed height $h_1^*$	Free lift $h_2$	Lift height $h_3$	Extended height $h_4$
	<b>EJC 212/214</b>				<b>EJC 216</b>				<b>EJC 220</b>			
Two-stage mast ZT	1750	100	2500	2977	1750	100	2400	2927	1950	100	2500	3177
	1850	100	2700	3177	1850	100	2600	3127	–	–	–	–
	1950	100	2900	3377	1950	100	2800	3327	2100	100	2800	3477
	2100	100	3200	3677	2100	100	3100	3627	–	–	–	–
	2300	100	3600	4077	2300	100	3500	4027	2450	100	3500	4177
	–	–	–	–	2450	100	3800	4327	–	–	–	–
	2550	100	4100	4577	2550	100	4000	4527	–	–	–	–
	2650	100	4300	4777	2650	100	4200	4727	–	–	–	–
Two-stage mast ZZ	1700	1223	2500	2977	1700	1173	2400	2927	1900	1223	2500	3177
	1900	1423	2900	3377	1900	1373	2800	3327	2050	1373	2800	3477
	2050	1573	3200	3677	2050	1523	3100	3627	–	–	–	–
	2250	1773	3600	4077	2250	1723	3500	4027	2400	1723	3500	4177
	2500	2023	4100	4577	2500	1973	4000	4527	–	–	–	–
	2600	2123	4300	4777	2600	2073	4200	4727	–	–	–	–
Three-stage mast DZ	1830	1356	4090	4565	1830	1306	3990	4515	1850	1159	3510	4209
	1900	1426	4300	4775	1900	1376	4200	4725	–	–	–	–
	2030	1556	4700	5175	2030	1506	4600	5125	2080	1389	4200	4899
	2250	1776	5350	5825	2250	1726	5250	5775	2280	1589	4800	5499

\* ZT mast: at 100 mm free lift



# Make use of the advantages

## Maximum safety

- The 4-wheel EJC is very stable with its offset drive. This ensures safe and effortless manoeuvring, particularly during stacking and retrieval.
- High residual capacities are achieved with the torsion resistant, clear view mast. Giving high utilisation of all storage locations.
- The low mounted tiller reduces the risk of foot injuries due to a larger distance between operator and chassis, this increases the safety for the operator.
- The offset tiller provides excellent visibility past the load for fast, safe operation. The operator is secure within the truck contours during travel.



High residual capacities promote truck versatility

- Only authorised employees have access to the truck with CanCode (optional). The truck is activated by PIN instead of an ignition key.
- Constant travel speed on gradients. The advantage: No uncontrolled and dangerous roll-back.

## Minimum operating costs

- Wear-free electro-magnetic brake.
- No carbon brushes – the drive motor is maintenance-free.

## Special protection for electric components

- The enclosing to IP protection class 54 reduced the possibility of humidity and dust ingress, and increases the reliability of components and cabling.

## Highly productive product throughput

- 3-phase AC technology: Efficient goods throughput and fast working cycles are achieved due to powerful acceleration and high top speed. The weight of the load has virtually no effect on acceleration and maximum travel speed.
- Short lift times (even with full load) through compact 3 kW pump motor.
- Smooth depositing of pallets with automatic deceleration of lowering speed (optional).
- Control of all functions with the multi-functional tiller head.



Excellent visibility through slim mast

- Effortless steering, especially during manoeuvring with tiller in upright position, and crawl speed button via electric steering (optional).

## Additional equipment

- ProTrac support wheel.
- Vertical load guard.
- Sideways battery removal.
- Cold store design.

## Jungheinrich UK Ltd.

### Head Office:

Sherbourne House · Sherbourne Drive  
Tilbrook · Milton Keynes MK7 8HX  
Phone 01908 363100  
Fax 01908 363180

info@jungheinrich.co.uk  
www.jungheinrich.co.uk



**JUNGHEINRICH**  
Well worthwhile