

**Maintenance free, AC electric drive motor  
for excellent energy efficiency**

**High performance version for  
unsurpassed productivity and throughput**

**“JetPilot” electric steering wheel  
for easy and comfortable handling**

**An extensive range of accessories  
for individual customisation**

**Rising stand-on platform  
for 2<sup>nd</sup> level order picking (optional)**



## ECE 220/225

### Horizontal order picker (2000/2500 kg)

Through a combination of the latest technology and numerous ergonomic design features, the Jungheinrich ECE 220/225 optimises both cost and speed of order picking.

A 3 Phase AC drive motor ensures the best performance in all applications. The advantages: High acceleration and travel speed with low energy consumption, which together with regenerative braking delivers more hours in operation and higher throughput. The fine tuning between drive motor and control, together with a reduction in service and maintenance “by the omission of carbon brushes” combine further with the advantages to offer the best in optimised efficiency.

The ergonomic advantages optimise the interface between person, machine and load. The immediate proximity of the operator and the load together with the stand-on platform, form two main points for safe and efficient order picking. The rising stand-on platform (optional) allows comfortable and fast order picking, also from the second rack-level.

The ECE has a choice of two electric steering systems: steering by tiller arm or using the “JetPilot” steering wheel. The advantages of electric tiller steering: light steering with only a 60° degree tiller arm movement required for a 90° steering direction change. The operator and tiller arm always remain inside

the contours of the truck. The advantages of the JetPilot steering wheel: Intuitive controls plus safe and secure grip like in a car, create first class operator comfort. No twisting of the operator body when travelling through curves (therefore relief from neck and spine stress). Single hand control with automatic return of the steering wheel to straight-ahead travel.

With its high drive performance and ergonomically optimised operator workplace, the ECE stands at the forefront, performing always at its best, also in the most demanding of applications.

# ECE 220/225

ECE 220/225

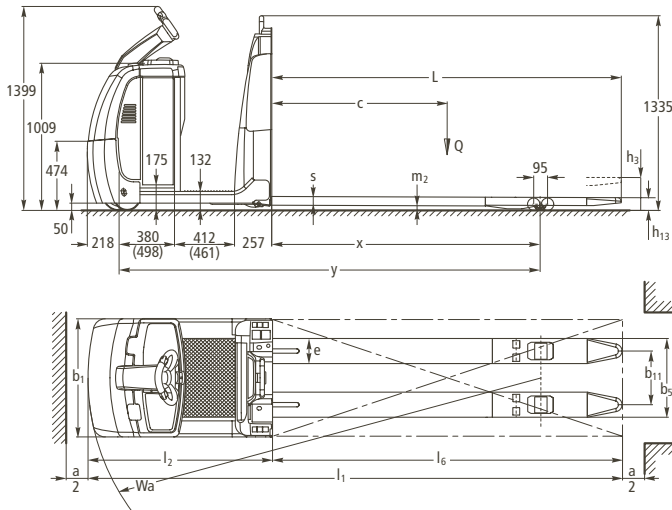

ECE 220/225 HP

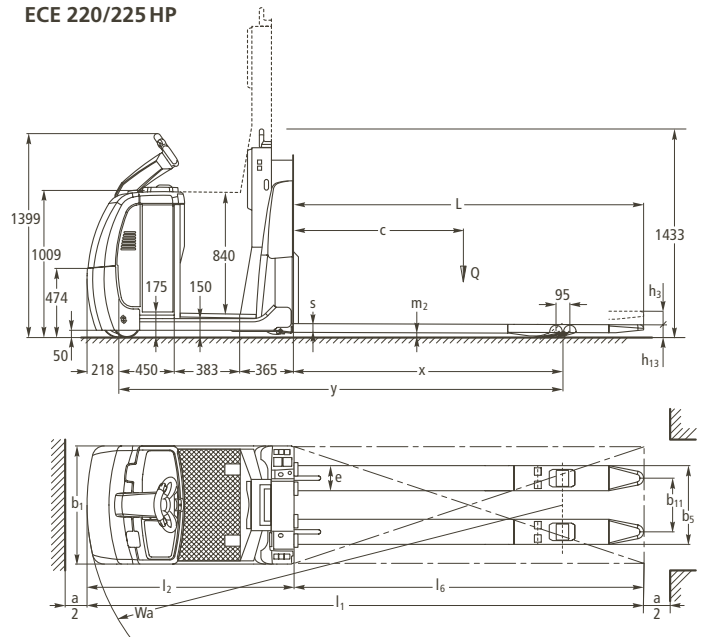

The values in brackets are valid for the ECE 220/225 XL

Fork dimensions ECE 220/225 incl. XL and HP (mm)

l	Fork overhang	Capacity (t)	l <sub>1</sub> <sup>1)</sup>	y <sup>1)2)</sup>	Wa <sup>1)2)</sup>	x <sup>2)</sup>	Ast <sup>1)</sup>
1000	186	2.0	2267	1863	2081	814	2467
1150	186	2.0	2417	2013	2231	964	2667
1250	186	2.0	2517	2113	2331	1064	2717
1400	186	2.5	2667	2263	2481	1214	2867
1400	560	2.0	2667	1891	2109	842	2867
1450	560	2.0	2717	1941	2159	892	2917
1600	186	2.5	2867	2463	2681	1414	3067
1600	560	2.0	2867	2091	2309	1042	3067
1880	560	2.5	3147	2371	2589	1322	3347
1950	560	2.5	3217	2441	2659	1392	3467
2180	800	2.5	3447	2429	2647	1380	3647
2280	800	2.5	3547	2529	2747	1482	3747
2310	186	2.5	3577	3173	3391	2124	3797
2400	560	2.5	3667	2891	3107	1840	3867
2400	800	2.5	3667	2649	2867	1600	3867
2430	900	2.5	3697	2579	2797	1530	3905
2550	800	2.5	3817	2799	3017	1750	4017
2850	800	2.5	4117	3099	3317	2050	4317
2900	800	2.5	4167	3149	3367	2100	4367
3100	800	2.5	4367	3349	3567	2300	4567

1) ECE 220/225 XL: values +167 mm; ECE 220/225 HP: values +150 mm

2) with raised load section: values -89 mm

# Technical Data in line with VDI 2198 as at: 06/2010

Identification	1.1	Manufacturer (abbreviation)		Jungheinrich	Jungheinrich	Jungheinrich	1.1
	1.2	Manufacturer's type designation		<b>ECE 225</b>	<b>ECE 225 XL</b>	<b>ECE 225 HP</b>	1.2
	1.3	Drive		electric	electric	electric	1.3
	1.4	Operator type		order picker	order picker	order picker	1.4
	1.5	Load capacity/rated load	Q (t)	2.5	2.5	2.5	1.5
	1.6	Load centre distance	c (mm)	1200	1200	1200	1.6
	1.8	Load distance, centre of drive axle to fork	x (mm)	1600	1600	1600	1.8
	1.9	Wheelbase	y (mm)	2649 <sup>1)</sup>	2816 <sup>1)</sup>	2799 <sup>1)</sup>	1.9
	Weights	2.1	Service weight incl. battery (see line 6.5)	kg	1114	1215	1270
2.2		Axle loading, laden front/rear	kg	1173/2441	1233/2482	1465/2305	2.2
2.3		Axle loading, unladen front/rear	kg	853/261	933/282	970/300	2.3
Wheels, Chassis	3.1	Tyres		Vulkollan®	Vulkollan®	Vulkollan®	3.1
	3.2	Tyre size, front	mm	Ø230 x 78	Ø230 x 78	Ø230 x 78	3.2
	3.3	Tyre size, rear	mm	Ø85 x 85	Ø85 x 85	Ø85 x 85	3.3
	3.4	Additional wheels (dimensions)	mm	Ø180 x 65	Ø180 x 65	Ø180 x 65	3.4
	3.5	Wheels, number front rear (x = driven wheels)		1 + 1 x/4	1 + 1 x/4	1 + 1 x/4	3.5
	3.6	Tread, front	b <sub>10</sub> (mm)	485	485	485	3.6
	3.7	Tread, rear	b <sub>11</sub> (mm)	338/368/498	338/368/498	338/368/498	3.7
Basic Dimensions	4.4	Lift	h <sub>3</sub> (mm)	125	125	125	4.4
	4.9	Height of tiller in drive position min./max.	h <sub>14</sub> (mm)	1399	1399	1399	4.9
	4.15	Height, lowered	h <sub>13</sub> (mm)	90	90	90	4.15
	4.19	Overall length	l <sub>1</sub> (mm)	3667	3834	3817	4.19
	4.20	Length to face of forks	l <sub>2</sub> (mm)	1267	1434	1417	4.20
	4.21	Overall width	b <sub>1</sub> /b <sub>2</sub> (mm)	810/-	810/-	810/-	4.21
	4.22	Fork dimensions	s/e/l (mm)	60/172/2400	60/172/2400	60/172/2400	4.22
	4.25	Distance between fork-arms	b <sub>3</sub> (mm)	510/540/670	510/540/670	510/540/670	4.25
	4.32	Ground clearance, centre of wheelbase	m <sub>2</sub> (mm)	30	30	30	4.32
	4.34	Aisle width for pallets 800x1200 lengthways	Ast (mm)	3867 <sup>2)</sup>	4034 <sup>2)</sup>	4017 <sup>2)</sup>	4.34
	4.35	Turning radius	Wa (mm)	2867	3034	3017	4.35
Performance Data	5.1	Travel speed, laden/unladen	km/h	9.5/12.5	9.3/12.3	9.5/12.5	5.1
	5.2	Lift speed, laden/unladen	m/s	0.06/0.07	0.06/0.07	0.06/0.07	5.2
	5.3	Lowering speed, laden/unladen	m/s	0.06/0.05	0.06/0.05	0.06/0.05	5.3
	5.8	Max. gradeability, laden/unladen	%	6/15	6/15	6/15	5.8
	5.10	Service brake		electromagnetic	electromagnetic/ electro-generative	electromagnetic	5.10
Electric Engine	6.1	Drive motor rating S <sub>2</sub> 60 min	kW	2.8	2.8	2.8	6.1
	6.2	Lift motor rating at S <sub>3</sub> 15 %	kW	1.5	1.5	1.5	6.2
	6.3	Battery acc. to DIN 43531/35/36 A, B, C, no		no	no	no	6.3
	6.4	Battery voltage, nominal capacity K <sub>s</sub>	V/Ah	24/465	24/620	24/465	6.4
	6.5	Battery weight	kg	370	450	370	6.5
	6.6	Energy consumption acc. to VDI cycle	kWh/h	0.74	0.76	-	6.6
Others	8.1	Type of drive control		AC SpeedControl	AC SpeedControl	AC SpeedControl	8.1
	8.4	Sound level at the driver's ear according to EN 12053	dB (A)	67	67	67	8.4

- 1) load section lowered: +90 mm  
2) diagonal according to VDI: +94 mm

# Make use of the advantages

## Innovative AC technology

More performance with a reduced operating costs. Offering you these advantages:

- Higher energy efficiency with lower energy consumption.
- Rapid acceleration for high productivity.
- Quick and safe changing of travel direction without a pause in neutral.
- No carbon brushes – the drive motor is maintenance free.
- 2 year drive motor warranty.

## Comfortable operation

The advanced electronic drive control "Speed-Control" offers comfortable and safe travel with drive characteristic adjustment for all applications.

- The travel speed set by the driver on the control switch is maintained irrespective of operation e.g. during travel up or down an incline or ramp.
- 3 programmable drive settings to cater for the travel demands of every application.
- Regenerative braking with energy recovery when reducing travel speed.



Comfortable operation and fast order picking

## Rugged construction for the hardest of applications

- Chassis from high quality steel.
- Extra-high raised chassis apron on front cover.



Order picking from the second rack-level with rising stand-on platform

- Tension proof fork sections with strong pull rods – no bending even with heavy loads and long forks.
- Carrying capacity 2,5 t for up to 3 pallets simultaneously.

## Comfortable and safe order picking

The hydraulic rising stand-on platform (optional) offers the best basis for frequent storage and retrieval from the second rack-level.

- Safe and fast rising and lowering of the operator, up to the height of the battery cover.
- Comfortable control of the platform by a foot controlled button, therefore the operator's hands remain free.
- High order picking performance due to the immediate proximity of the operator to the load.
- The "JetPilot" can be raised together with the platform allowing the positioning of the truck even under raised platform situations (optional).

## Longer operational time

Energy saving 3 Phase technology and high battery capacity allow longer time on the job.

- Standard version battery 3 PzS 465 Ah.
- High performance version XL. Battery 4PzS 465/620 Ah.
- Lateral battery withdrawal (optional) for multi-shift applications.

## Always informed

Extensive display provides a complete overview:

- "CanDis" (optional) informs of battery state of charge, operational hours and fault codes.
- Activation of the truck using a PIN and a choice of 3 travel programme settings by keypad (optional).
- Programmable travel parameters by CanDis and CanCode (optional).

## Individual steering

Selectable steering options for customised application.

- Electric tiller arm with steering ratio.
- Electric steering with JetPilot.
- Curve Control (optional): automatic speed reduction when travelling through curves.



JetPilot – exclusive from Jungheinrich

## Additional accessories

An extensive range of accessories allow individual adjustment to your application:

- Edging buttons located in the backrest on both sides of the truck for pedestrian edging operations.
- A variety of backrest designs
- Extra collision protection from steel or rubber.
- Additional accessories for working at the second rack-level.
- Holder for radio data transmission equipment.

## Jungheinrich UK Ltd.

Head Office:

Sherbourne House · Sherbourne Drive  
Tilbrook · Milton Keynes MK7 8HX  
Phone 01908 363100  
Fax 01908 363180

info@jungheinrich.co.uk  
www.jungheinrich.co.uk



Jungheinrich trucks conform to the European Safety Requirements.

**JUNGHEINRICH**  
Well worthwhile