

Hydrostatic drive for excellent drive comfort and productivity

Low fuel consumption

Generously designed operator workplace

Excellent stability during travel due to extremely low centre of gravity and safety steering axle

Active safety systems (optional)

Independently suspended drive train



DFG/TFG 425s–435s

Diesel and LPG forklifts with hydrostatic drive (2500, 3000, 3500 kg)

Jungheinrich Diesel and LPG forklift trucks with hydrostatic drive provide a high handling efficiency, particularly in shuttle operations (e.g. trailer and loading bay operations). The power of this drive technology is demonstrated to full advantage: dynamic acceleration, rapid direction changes and precise driving characteristics. With 5 drive modes, the performance characteristics can be adapted to the requirements of numerous varied applications.

State-of-the-art engines from the automobile industry facilitate precise operation and optimum productivity combined with low fuel consumption by means of their electronic control systems. All motors are distinguishable by low exhaust emission and comply with at least the current EU regulations. A regulated 3-way catalyser for LPG as well as soot filter systems for Diesel trucks are optionally available.

The workplace is optimally designed with the operator in mind. It provides safety, protects the operator's health and ensures relaxed and concentrated operation – the best prerequisite for high productivity throughout the shift.

**JUNGHEINRICH**

DFG/TFG 425s–435s

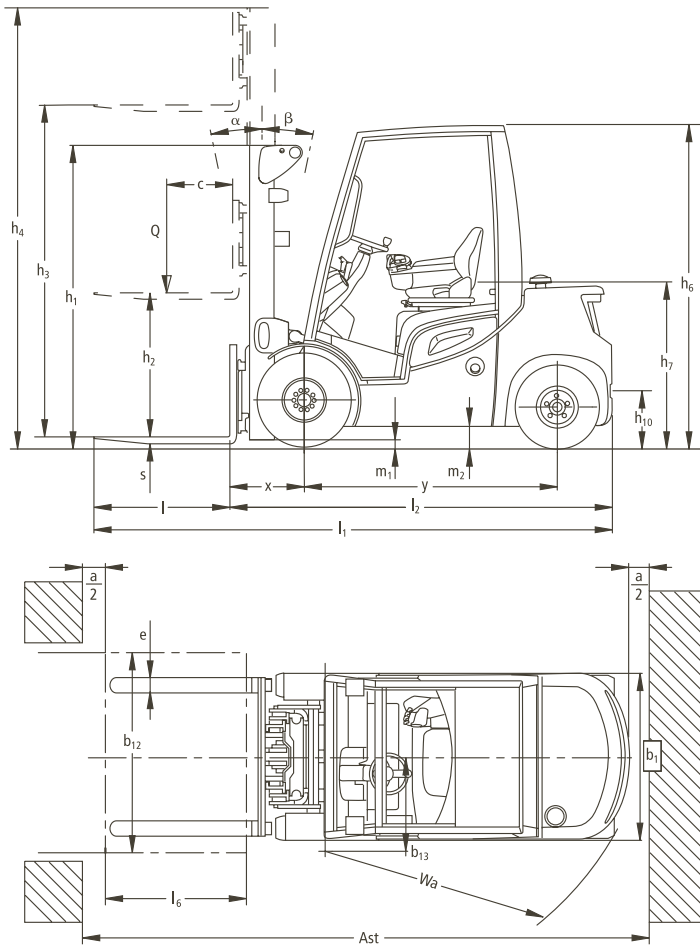

Capacity

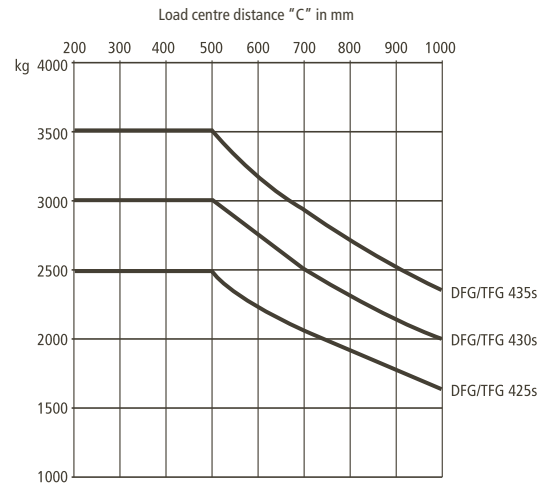

Mast table DFG/TFG 425s–435s														
Designation	Lift height h_3 mm		Free lift h_2 mm			Closed height h_1 mm			Extended height h_4 mm			Tilt forward/backward α/β (°)		
	DFG/TFG 425s/430s	DFG/TFG 435s	DFG/TFG 425s	DFG/TFG 430s	DFG/TFG 435s	DFG/TFG 425s	DFG/TFG 430s	DFG/TFG 435s	DFG/TFG 425s	DFG/TFG 430s	DFG/TFG 435s	DFG/TFG 425s/430s	DFG/TFG 435s	
Two-stage mast ZT	2900	2900	150	150	150	2115	2133	2228	3510	3688	3683	6/8	6/8	
	3100		150	150		2215	2233		3710	3888		6/8		
	3300	3300	150	150	150	2315	2333	2428	3910	4088	4083	6/8	6/8	
	3500		150	150		2415	2433		4110	4288		6/8		
	3700		150	150		2515	2533		4310	4488		6/8		
		3800			150				2678			4583		6/8
	4000		150	150		2665	2683		4610	4788		6/8		
	4300	4300	150	150	150	2865	2883	2978	4910	5088	5083	6/8	6/8	
	4500		150	150		2965	2983		5110	5288		6/8		
	4700		150	150		3065	3083		5310	5488		6/6		
	4800			150				3228			5583		6/6	
	5000		150	150		3215	3233		5610	5788		6/6		
	5500		150	150		3515	3533		6110	6288		6/6		
	5800		150	150		3665	3683		6410	6588		6/6		
	6000		150	150		3765	3783		6610	6788		6/6		
Two-stage mast ZZ	2900		1480	1380		2080	2098		3500	3618		6/8		
	3100		1580	1480		2180	2198		3700	3818		6/8		
	3300		1680	1580		2280	2298		3900	4018		6/8		
	3500		1780	1680		2380	2398		4100	4218		6/8		
	3700		1880	1780		2480	2498		4300	4418		6/8		
	4000		2030	1930		2630	2648		4600	4718		6/8		
	4300		2230	2130		2830	2848		4900	5018		6/8		
4500		2330	2230		2930	2948		5100	5218		6/8			
Three-stage mast DZ	4400		1480	1380		2080	2098		5000	5118		6/8		
	4700	4500			1430			2193			5263		6/6	
		4800	1580	1480		2180	2198		5300	5418		6/6	6/6	
	5000		1680	1580		2280	2298		5600	5718		6/6	6/6	
		5300	1880	1780	1730	2480	2498		6100	6218		6/6	6/6	
	5500		1880	1780		2480	2498		6100	6218		6/6	6/6	
	6000		2080	1980		2680	2698		6600	6718		6/6	6/6	
	6500	6300			2130			2893			7063		6/6	
7000		2280	2180		2880	2898		7100	7218		6/6	6/6		
		2480	2380		3080	3098		7600	7718		6/6	6/6		

Technical data in line with VDI 2198 as at: 04/2008

		Jungheinrich		Jungheinrich		Jungheinrich							
		DFG 425s	TFG 425s	DFG 430s	TFG 430s	DFG 435s	TFG 435s						
Identification	1.1	Manufacturer (abbreviation)		Jungheinrich		Jungheinrich		1.1					
	1.2	Manufacturer's type designation		DFG 425s	TFG 425s	DFG 430s	TFG 430s	DFG 435s	TFG 435s	1.2			
	1.3	Drive		Diesel	LPG	Diesel	LPG	Diesel	LPG	1.3			
	1.4	Operator type		seat		seat		seat		1.4			
	1.5	Load capacity/rated load	Q (t)	2.5		3		3.5		1.5			
	1.6	Load centre distance	c (mm)	500		500		500		1.6			
	1.8	Load distance, centre of drive axle to fork	x (mm)	473 ¹⁾		478 ¹⁾		483 ¹⁾		1.8			
	1.9	Wheelbase	y (mm)	1750		1820		1880		1.9			
	Weights	2.1	Service weight		4080		4376		4821		2.1		
2.2		Axle loading, laden front/rear		5833/747		6578/868		7339/982		2.2			
2.3		Axle loading, unladen front/rear		1943/2137		1958/2488		2009/2812		2.3			
Wheels, Chassis	3.1	Tyres		SE		SE		SE		3.1			
	3.2	Tyre size, front		7.00-12		27x10-12		27x10-12		3.2			
	3.3	Tyre size, rear		6.50-10		6.50-10		6.50-10		3.3			
	3.5	Wheels, number front rear (x = driven wheels)		2x/2		2x/2		2x/2		3.5			
	3.6	Tread, front	b ₁₀ (mm)	1000		1060		1060		3.6			
	3.7	Tread, rear	b ₁₁ (mm)	942		942		942		3.7			
	Basic Dimensions	4.1	Tilt of mast/fork carriage forward/backward		α/β (°)		6/8		6/8		4.1		
4.2		Closed mast height		h ₁ (mm)		2315		2333		4.2			
4.3		Free lift		h ₂ (mm)		150		150		4.3			
4.4		Lift (standard mast)		h ₃ (mm)		3300		3300		4.4			
4.5		Height, mast extended		h ₄ (mm)		3910		4088		4.5			
4.7		Height of overhead guard (cabin)		h ₆ (mm)		2220		2238		4.7			
4.8		Seat height/stand height		h ₇ (mm)		1058		1076		4.8			
4.12		Coupling height		h ₁₀ (mm)		377		387		4.12			
4.19		Overall length		l ₁ (mm)		3763		3858		4.19			
4.20		Length to face of forks		l ₂ (mm)		2613		2708		4.20			
4.21		Overall width		b ₁ /b ₂ (mm)		1184		1320		4.21			
4.22		Fork dimensions		s/e/l (mm)		40/120/1150		45/125/1150		4.22			
4.23		Fork carriage ISO 2328, class/type A, B		2A		3A		3A		4.23			
4.31		Ground clearance, laden, below mast		m ₁ (mm)		125		143		4.31			
4.32		Ground clearance, centre of wheelbase		m ₂ (mm)		130		148		4.32			
4.33		Aisle width for pallets 1000x1200 crossways		Ast (mm)		3958		4060		4.33			
4.34		Aisle width for pallets 800x1200 lengthways		Ast (mm)		4158		4260		4.34			
4.35		Turning radius		Wa (mm)		2285		2377		4.35			
4.36	Internal turning radius		b ₁₃ (mm)		617		641		4.36				
Performance Data	5.1	Travel speed, laden/unladen		km/h		19.6/19.6		20.8/20.8		5.1			
	5.2	Lift speed, laden/unladen		m/s		0.56/0.56		0.56/0.56		5.2			
	5.3	Lowering speed, laden/unladen		m/s		0.56/0.56		0.56/0.56		5.3			
	5.5	Drawbar pull, laden/unladen		N		19160		18100		5.5			
	5.7	Gradeability, laden/unladen		%		27		24		5.7			
	5.9	Acceleration time, laden/unladen		s		4.9/4.4	5.7/5.0	5.4/4.6	5.9/5.1	5.7/4.7	6.1/5.2	5.9	
5.10	Service brake		hydrostatic		hydrostatic		hydrostatic		5.10				
Combustion Engine	7.1	Engine manufacturer/type		VW/BYA	VW/BEF	VW/BYA	VW/BEF	VW/BYA	VW/BEF	7.1			
	7.2	Engine power acc. to ISO 1585		kW		43		38		7.2			
	7.3	Rated speed		min ⁻¹		2500		2700		7.3			
	7.4	No. of cylinders/displacement		/cm ³		4/1968		4/1980		7.4			
	7.5	Fuel consumption acc. to VDI cycle		l/h, kg/h		3.2		2.8		3.5	3	3.7	3.2
Others	8.1	Type of drive control		hydrostatic		hydrostatic		hydrostatic		8.1			
	8.2	Operating pressure for attachments		bar		160		160		190	8.2		
	8.3	Oil volume for attachments		l/min		30		30		30	8.3		
	8.4	Sound level at the driver's ear according to EN 12 053		dB(A)		75	77	75	77	75	77	8.4	
	8.5	Towing coupling, type DIN		DIN 15170 type H		DIN 15170 type H		DIN 15170 type H		8.5			

1) + 25 mm for DZ mast

Make use of the advantages

Ergonomic operator workplace

Comfortable and with a positive influence towards productivity due to the exemplary ergonomics:

- Easy and safe access due to a large step easily visible from above.
- Floating Cab: vibration isolation due to damped mounting of the power train and operator workplace module.
- Height and rake adjustable, slim steering column with memory function.
- Maximum freedom of movement during entry and exit: the steering column tilts forward by means of a simple pull on the memory function lever.
- Excellent all-round visibility due to special roof and scuttle design.
- SOLO-PILOT, Comfort Display and operating console are integrated into the right armrest and are thus particularly easy to operate and read. The armrest is both vertically and horizontally adjustable.
- Comfortable working environment in any weather due to comfort cabs in various designs (optional).



Comfortable and productivity inspiring workplace

Active safety

The new Hydrostatic already offers an extensive safety package as standard:

- Deactivation of hydraulic functions if seat is unoccupied.
- No uncontrolled roll-back on ramps or inclines due to the automatic parking brake, even with the motor switched off.

- Excellent stability due to extremely low inherent centre of gravity and high-mounted steering axle.

A range of additional options provide even more safety for the operator, the forklift and the load:

- Access Control: The access control system allows operation of the forklift only if "seat occupied" and "safety belt locked" recognition are activated in a defined sequence.
- Drive Control: Automatic travel speed reduction when cornering (analogue to Jungheinrich Curve Control). Additional travel speed reduction occurs with lift heights in excess of approx. 1500 mm.
- Lift Control (includes "Drive Control"): Automatic mast tilt speed reduction occurs with lift heights in excess of approx. 1500 mm. Tilt angle is displayed via an individual display unit. Sideshift centre position selection via push button.

Handling efficiency and drive characteristics

Key advantages of hydrostatic drive:

- Electronic control for precise adjustment of drive and hydraulic functions.
- Optimum handling performance particularly in shuttle operation.
- Stepless power transmission and high starting torques.
- 5 electronically selectable drive modes ensure optimum performance parameters for every application.
- Automatic engine speed increase during lifting and lowering.
- Very precise control of travel speed: truck "hangs on the accelerator".
- Optional double pedal operation.
- Low maintenance costs due to direct drive without wearing parts, such as clutch, differential and gears.

Intelligent electronics

- Splash-proof electronic controllers (IP 64) connected to the CAN-Bus system for drive and hydraulic functions.

- 74 Ah 12 V battery/90 A 3-phase AC generator (140 A optional).
- Electronically controlled motors.
- TFG with maintenance-free electronic ignition system.
- Sensitive adjustment of hydraulic functions via electromagnetic valves.

Tyres

Superelastic tyres as standard; choices of non-marking SE and pneumatic tyres also available.

Brakes

The hydrostatic drive facilitates completely wear-free braking:

- Frequent brake pedal operation is no longer necessary.
- In addition, spring-loaded laminated parking brake in oil bath as a maintenance-free, enclosed system.
- Safety on ramps: The parking brake is activated automatically when the truck stands still or the engine is switched off.

Hydraulics

The high performance filter system ensures clean hydraulic oil and a long service life of all components.

- Combined suction and return flow filter system for optimum cold run characteristics.
- Hydraulic tank integrated in chassis.
- Ventilation of hydraulic tank via the filter.
- Pressure relief valves protect against excess pressure and overloading.

Mast

All mast components are designed for optimum visibility, maximum stability and long service life:

- Slender mast profiles and lift cylinders positioned at the rear for maximum view.
- End cushioning on mast and tilt cylinders for increased handling safety.

Additional equipment

Various options and attachments are available to suit different application requirements.

**Jungheinrich
Export AG & Co. KG**

Am Stadtrand 35
D-22047 Hamburg
Telephone +49 40 6948-0
Telefax +49 40 6948-3604

info@jungheinrich.com
www.jungheinrich.com

Jungheinrich AG
ISO 9001, ISO 14001
Certification of Quality and
Environment Management.



Jungheinrich trucks
conform to the European
Safety Requirements.



JUNGHEINRICH
Well worthwhile