

**Corrosion resistant  
and protected against  
acids and brine**

**Grease nipples  
on moving parts  
for long service life**

**Electric lift (AMX I10e)**

**Glass bead blasted  
surfaces for easy cleaning**

**Energy-saving:  
Battery is not lifted  
together with the load**



## **AMX I10/I10p AMX I10e/I10ep**

### **Scissor lift pallet truck in stainless steel design (1000 kg)**

The Inox designs of the scissor lift pallet trucks AMX I10/I10e are the ideal trucks for the transport of goods in all areas where absolute hygiene is required. The advantages of the Inox series take effect in damp or aggressive environments.

Individually adjustable to every application, there is a wide choice. With decades of experience in stainless steel hand pallet trucks, the result is reliable and thoroughly robust trucks. Whether for slaughterhouses, fish processing or the chemical/pharmaceutical

industry: The scissor lift pallet trucks offer the right solution.

# AMX I10/I10p and AMX I10e/I10ep

AMX I10/I10p

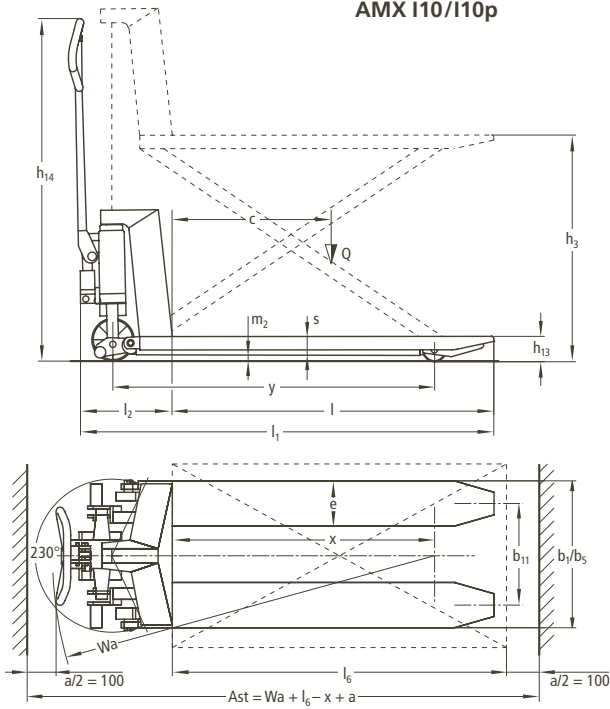

AMX I10e/I10ep

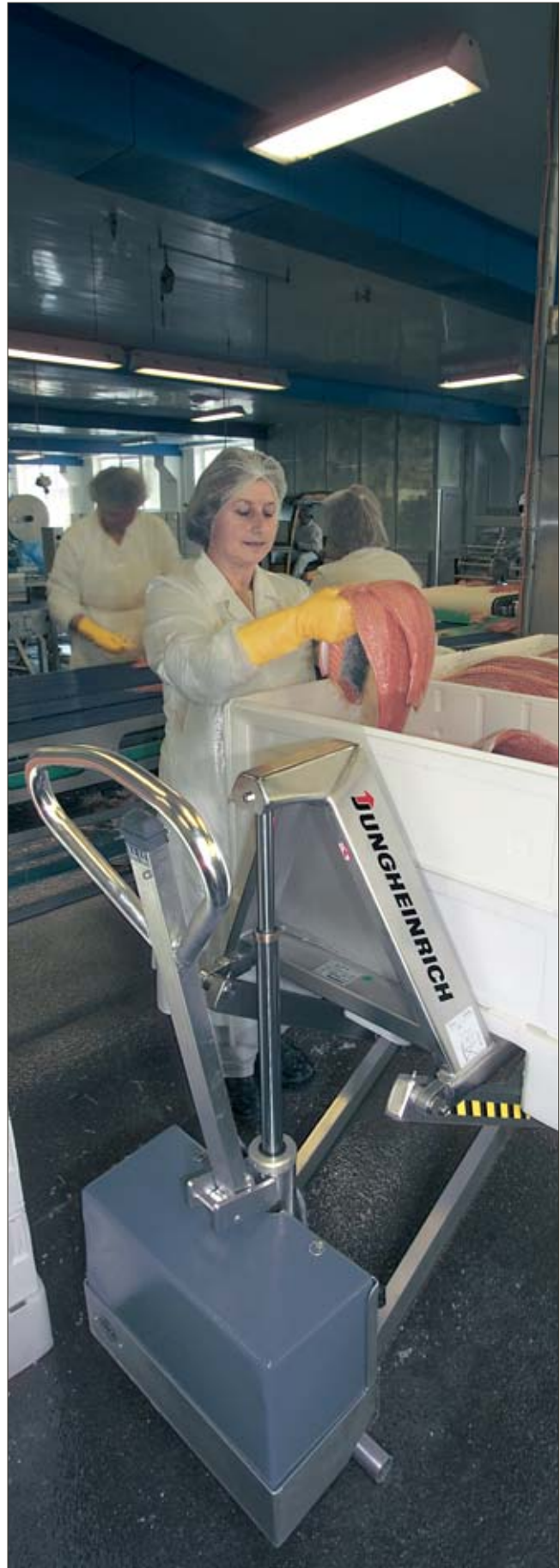
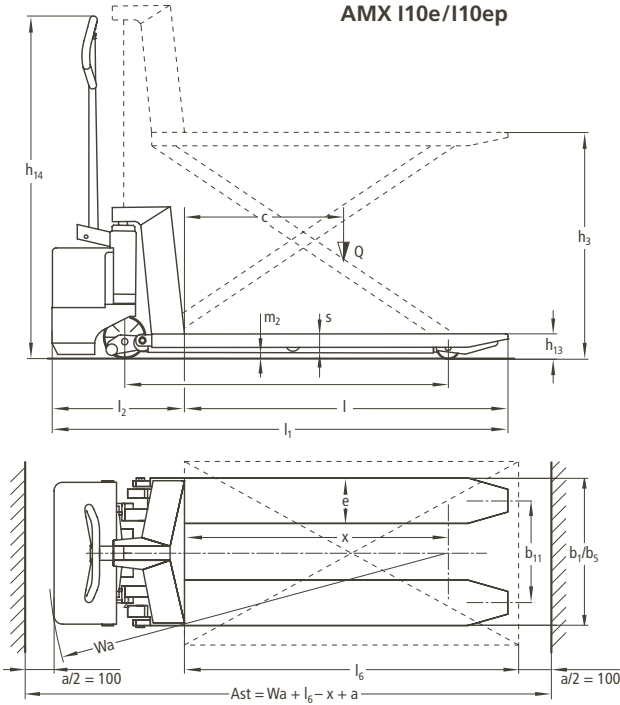

# Technical Data in line with VDI 2198 as at: 02/2009

Identification	1.1	Manufacturer (abbreviation)		Jungheinrich	Jungheinrich	1.1
	1.2	Manufacturer's type designation		<b>AMX 110/I10p</b>	<b>AMX 110e/I10ep</b>	1.2
	1.3	Drive		manual	electric (lift)	1.3
	1.4	Type of operation		pedestrian	pedestrian	1.4
	1.5	Load capacity/rated load	Q (t)	1	1	1.5
	1.6	Load centre distance	c (mm)	600	600	1.6
	1.8	Load distance, centre of drive axle to fork	x (mm)	925	925	1.8
	1.9	Wheelbase	y (mm)	1140	1140	1.9
	Weights	2.1	Service weight incl. battery (see line 6.5)	kg	108	140
2.2		Axle loading, laden front/rear	kg	358/750	367/753	2.2
2.3		Axle loading, unladen front/rear	kg	70/38	85/35	2.3
Wheels, Chassis	3.1	Tyres		N; V	N; V	3.1
	3.2	Tyre size, front		150x42; 150x40	150x42; 150x40	3.2
	3.3	Tyre size, rear		80	80	3.3
	3.5	Wheels, number front/rear (x = driven wheels)		2/2 or 2/4	2/2 or 2/4	3.5
	3.6	Track width, front	b <sub>10</sub> (mm)	145	145	3.6
	3.7	Track width, rear	b <sub>11</sub> (mm)	440	440	3.7
	Basic Dimensions	4.4	Lift height	h <sub>3</sub> (mm)	800	800
4.9		Height of tiller in drive position min. / max.	h <sub>14</sub> (mm)	1195	1195	4.9
4.14		Standing height, elevated	h <sub>12</sub> (mm)	800	800	4.14
4.15		Lowered height	h <sub>13</sub> (mm)	90	90	4.15
4.19		Overall length	l <sub>1</sub> (mm)	1480	1580	4.19
4.20		Length to face of forks	l <sub>2</sub> (mm)	340	440	4.20
4.21		Overall width	b <sub>1</sub> /b <sub>2</sub> (mm)	540/680	540/680	4.21
4.22		Fork dimensions	s/e/l (mm)	50/163/1140	50/163/1140	4.22
4.25		Width over forks	b <sub>5</sub> (mm)	540	540	4.25
4.32		Ground clearance, centre of wheelbase	m <sub>2</sub> (mm)	28	28	4.32
4.34		Aisle width for pallets 800x1200 lengthways	Ast (mm)	1830	1890	4.34
4.35		Turning radius	Wa (mm)	1355	1415	4.35
Performance Data		5.3	Lowering speed, laden/unladen	m/s	0.15/0.093	0.08/0.05
Electric Engine	6.2	Lift motor rating at S <sub>3</sub> 10 %	kW	–	1.1	6.2
	6.4	Battery voltage, nominal capacity K <sub>s</sub>	V/Ah	–	12/60	6.4
	6.5	Battery dimensions	kg	–	20	6.5

# Make use of the advantages

## Easy to handle

- Easy to operate handle, for left-handed and right-handed operators.
- Special lowering valve for sensitive and proportional lowering of load.
- Short chassis dimension (340 mm) for safe operation even in most confined spaces.
- Skids on fork tips ensure easy pallet handling.

## Hygienic in every detail

- The enclosed fork tips ensure that splashes of dirt cannot reach the load.



Operating handle AMX I10



Operating handle AMX I10e

- Freely accessible or completely enclosed apertures allow effective cleaning with no hiding places for bacteria.
- Grease nipples on all moving parts.
- Lubricants suitable for foodstuff (class H1 and H2).

## Fast operation

The very narrow chassis dimension of 340 mm gives safe and easy operation even in most confined spaces. Skids on the fork tips ensure easy fork entry and exit.

## Back-protecting lift height

Support legs offer reliable protection up to a lift height of 800 mm.

## Effortless lifting and lowering

- A choice of manual hydraulics (AMX I10) or electro-hydraulics (AMX I10e) with 1.1 kW lift motor.
- Integrated pump motor with tank.
- Sensitive lowering via hand lever. The lowering valve is integrated in the pump. The hydraulics are protected against overloading by a pressure relief valve.

## Forks

Robust, torsion-resistant construction with enclosed fork tips.



Enclosed fork tips

## Wartungsfreie Batterie und eingebautes Ladegerät (AMX I10e)

- Eingebauter, elektronisch gesteuertes Ladegerät.
- Charging possible at any 230 V mains socket.
- Wartungsfreie 60 Ah battery.

Material comparison	AMX I10/I10e						AMX I10p/I10ep							
	Chassis	Tiller	Axle	Support arm lever	Yoke/reversing lever	Pressure rod	Pump	Chassis	Tiller	Axle	Support arm lever	Yoke/reversing lever	Pressure rod	Pump
Acid-resistant steel (AISI 316)	•							•						
Stainless steel (AISI 303/304)		•	•	•					•	•	•	•	•	• <sup>1)</sup>
Hot-dip galvanised					•	•								
Electro-galvanised							•							• <sup>2)</sup>

1) AMX I10ep 2) AMX I10p

## Jungheinrich UK Ltd.

Head Office:

Sherbourne House · Sherbourne Drive  
Tilbrook · Milton Keynes MK7 8HX  
Phone 01908 363100  
Fax 01908 363180

info@jungheinrich.co.uk  
www.jungheinrich.co.uk

Jungheinrich AG  
ISO 9001, ISO 14001  
Certification of Quality and  
Environment Management.



Jungheinrich trucks  
conform to the European  
Safety Requirements.



**JUNGHEINRICH**  
Well worthwhile